

Grease separator *EasyClean* round free Auto Mix & Pump NS 10 – 20 for free-standing installation



EN 1825

Tank

Manufactured from virgin, non-recycled polyethylene, for free-standing installation in frost-protected areas, with integrated sludge trap, with integrated sloped base directing wastewater into mixing / disposal pump, twin access covers with quick-release odour tight covers, with suction device installed for the joint disposal of contents of sludge trap and grease separator chamber, intake pipe 75 mm OD PN 10 in accordance with DIN 2501, Storz-B coupling R 2 1/2 for connection to the disposal vehicle. Inspection window with wiper. Inlet and outlet \varnothing 160 / 200 mm for the connection to PE-HD pipes according to DIN 19537, HT pipes according to DIN 19560, PP or AS.



Disposal System

Auto Mix & Pump with program-controlled disposal and rinsing device and Shredder-Mix-System, KESSEL disposal system Auto Mix & Pump with switching distribution and actuator valve, mixing and rinsing device via jet and conic nozzles, external pump(s) 3.0 kW (IP55, 400 V, 50 Hz; stronger pumps available on request) with integrated chopping mechanism and closure valve, 5 m cable length, 2 solenoid valves 1", with refill inlet in accordance with DIN 1988.

Control Unit for actuating the pump(s) with potential-free contact and Modbus.

Delivery: System completely assembled.

➤ **Accessories:** Sampling chamber, remote control, *TeleControl*, *SonicControl* level sensing system page 361 – 363, lifting stations see chapter "3"

➤ **Technical note:** page 360

➤ **Note:** Also available in 60 Hz / 400 V

without *SonicControl*

NS	Art. no.
NS 10	93 010.05/PVS
NS 15	93 015.05/PVS
NS 20	93 020.05/PVS

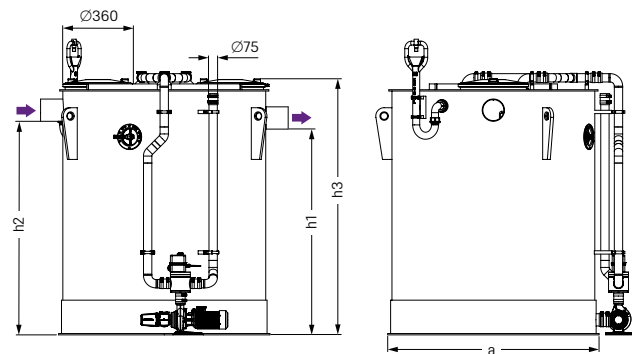

Pumping capacity

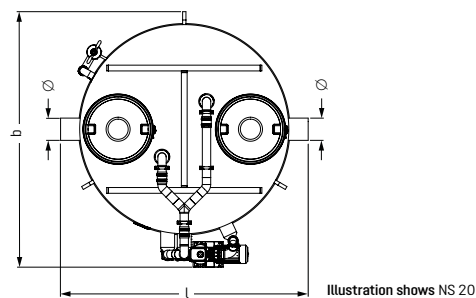
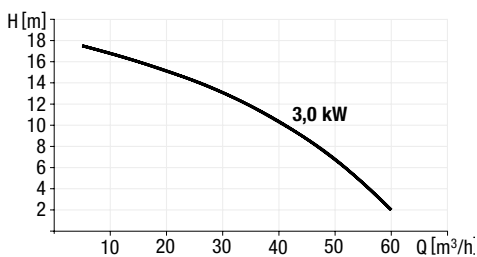

Illustration shows NS 20

NS	Ø (mm)	a (mm)	Installation dimension l × b (mm)	h1 (mm)	h2 (mm)	h3 (mm)	Sludge trap (l)	Water and grease (l)	Grease storage (l)	Total (l)
10	160	1570	1900 × 1915	1500	1570	1910	1000	1500	400	2500
15	200	1880	2230 × 2300	1550	1620	2020	1500	2300	600	3800
20	200	1880	2230 × 2300	1850	1920	2300	2000	2650	800	4650



Ø = Outer diameter