

Pumping station Aquapump XL Duo, GTF 4000-S1

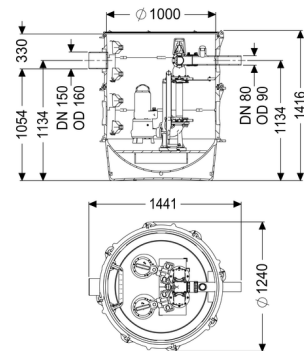

Article information

Item no.: 8743025
 GTIN: 4026092075791
 Price group: 60

Advantages

- Maximum safety
- Flexible installation
- Also handles large quantities of faecal-free wastewater

Description

The pumping station for faecal-free wastewater is equipped with a submersible pump and a backflow preventer. The collection tank made of permanently resistant polymer (PE) has an open pump tank with universal connection options. Quick-release closures enable the integrated components to be removed easily.

The station is controlled by a user-friendly control unit, which is optionally integrated in the building management system via a potential-free contact. Alternatively, alarm and collective fault messages can be output via a GSM interface.

The KESSEL modular system provides different engineering chamber options as accessories for the further layout.

Stainless steel pump removal chains available as accessory for each installation depth - Article number:

680528 = Length 2 m
 680529 = Length 3 m
 680530 = Length 4 m
 680531 = Length 5 m

Type of wastewater:
 Installation situation:

wastewater without sewage
 underground installation, floor slab installation

Version:

Type of system:	Twin pump station
Installation:	Wet installation
Shut-off valve:	Shut-off valve made of polymer
Pump control:	Control unit
Backflow preventer:	integrated
Access steps:	yes
Note on installation depth:	in combination with a chamber module
Passage seal for ventilation pipe (DN):	100 mm
Passage seal for conduit pipe (DN):	100 mm
Delivery state:	Pre-mounted for final assembly on site (pumps and sensor system must be fitted on site and control unit must be connected)

General characteristics:

Colour:	black
Standard:	EN 12050-2

Dimensions:

Length:	1,370 mm
Width:	1,240 mm
Height:	1,416 mm

Tank:

Number of inlets:	1 ST
Inlet nominal size (DN):	150
Inlet nominal size (OD):	160 mm
Inlet max. scoring (DN):	150 mm
Distance pipe bottom inlet to tank bottom:	1,054 mm
Distance from centre of outlet pipe to tank bottom:	1,134 mm
Distance from centre of inlet pipe to tank bottom:	1,134 mm
Pumping volume:	340 l
Pressure pipe connection:	horizontal
Pressure pipe connection (DN):	80 mm
Pressure pipe connection (OD):	90 mm
Groundwater resistant from lower edge of base section:	3,000 mm
Clear width of tank (LW):	1,000 mm

Pumping device:

Pump:	GTF 4000
Number of pumps:	2
Max. pumping capacity:	53 m ³ /h
Max. pumping height:	18 m
Operating mode:	S1
Power P1:	4 kW
Power P2:	3.4 kW
Speed:	2,900 U/min
Max. temperature (permanent) of conveyed material:	40 °C
Connection type:	Direct connection
Weight:	45 kg
Impeller type:	Multi-vane impeller
Length of mains cable for pump:	10 m
Rated current:	6.6 A
Protection class (pump):	IP 68 (20m)
Protection class:	I
Type of pump connection cable:	H07RN-F 7G 1.5 mm ²
Temperature monitoring:	integrated
Cos phi - power factor:	0.87
Insulation class:	H

Control:

Control unit:	Comfort
Operating voltage:	400 V
Mains frequency:	50 Hz
Self-diagnosis system (SDS):	yes
Battery buffering:	yes
Multi-line display:	yes
Log book function:	yes
GSM interface:	yes
Potential-free contact:	yes
Type of fuse required (electrical protection):	3 x C 32 A
Motor protection switch:	yes
Protection class control unit:	IP 54
Length of mains cable for control unit:	0 m
Type of level measurement:	hydrostatic
Level measurement instrument:	Level sensor
Alarm sensor:	Level sensor