

## Pumping station Aquapump XL Duo, STZ 3700-S1, ATEX

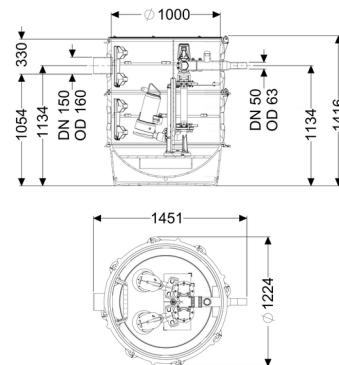

### Article information

Item no.: 8743019  
GTIN: 4026092075739  
Price group: 60

### Advantages

- Maximum safety
- Flexible installation
- Suitable for potentially explosive atmospheres

### Description

The pumping station with ATEX approval for faecal and faecal-free wastewater is equipped with a submersible pump, a backflow preventer and a shut-off valve for the pressure pipe. The collection tank made of permanently resistant polymer (PE) has an open pump tank (wet installation) with universal connection options.

The station is controlled by a user-friendly control unit, which is optionally integrated in the building management system via a potential-free contact. Alternatively, alarm and collective fault messages can be output via a GSM interface.

The KESSEL modular system provides different engineering chamber options as accessories for the further layout.

Stainless steel pump removal chain available as accessory. Art. no.

680 528 = length 2 m

680 529 = length 3 m

680 530 = length 4 m

680 531 = length 5 m

Type of wastewater:

wastewater with sewage

Installation situation:

underground installation, floor slab installation

### Version:

Type of system:	Twin pump station
Installation:	Wet installation
Shut-off valve:	Shut-off valve made of polymer
Pump control:	Control unit
Backflow preventer:	integrated
Access steps:	yes
Note on installation depth:	in combination with a chamber module
Passage seal for ventilation pipe (DN):	100 mm
Passage seal for conduit pipe (DN):	100 mm
Delivery state:	Pre-mounted for final assembly on site (pumps and sensor system must be fitted on site and control unit must be connected)

### General characteristics:

Colour:	black
Standard:	EN 12050-1

### Dimensions:

Length:	1,240 mm
Width:	1,240 mm
Height:	1,416 mm

### Tank:

Number of inlets:	1 ST
Inlet nominal size (DN):	150
Inlet nominal size (OD):	160 mm
Inlet max. scoring (DN):	150 mm
Distance pipe bottom inlet to tank bottom:	1,054 mm
Distance from centre of outlet pipe to tank bottom:	1,134 mm
Distance from centre of inlet pipe to tank bottom:	1,134 mm
Pumping volume:	300 l
Pressure pipe connection:	horizontal
Pressure pipe connection (DN):	50 mm
Pressure pipe connection (OD):	63 mm
Groundwater resistant from lower edge of base section:	3,000 mm
Clear width of tank (LW):	1,000 mm

### Pumping device:

Pump:	STZ 3700
-------	----------

Number of pumps:	2
Max. pumping capacity:	28 m <sup>3</sup> /h
Max. pumping height:	35 m
Operating mode:	S1
Power P1:	3.7 kW
Power P2:	3.1 kW
Speed:	2,900 U/min
Max. temperature (permanent) of conveyed material:	40 °C
Connection type:	Direct connection
Weight:	44 kg
Impeller type:	Macerator
Length of mains cable for pump:	10 m
Rated current:	6.4 A
Protection class (pump):	IP 68 (20m)
Protection class:	I
Type of pump connection cable:	H07RN8-F 6G 1.5 mm <sup>2</sup>
Temperature monitoring:	integrated
Cos phi - power factor:	0.82
Insulation class:	H

### Control:

Control unit:	Comfort
Operating voltage:	400 V
Mains frequency:	50 Hz
Self-diagnosis system (SDS):	yes
Battery buffering:	yes
Multi-line display:	yes
Log book function:	yes
GSM interface:	yes
Potential-free contact:	yes
Type of fuse required (electrical protection):	3 x C 32 A
Motor protection switch:	yes
Protection class control unit:	IP 54
Length of mains cable for control unit:	0 m
Type of level measurement:	hydrostatic
Level measurement instrument:	Level sensor
Alarm sensor:	Level sensor