

Lifting station Aqualift F Compact Mono, SPZ 1000, res. Floor sl., tileable

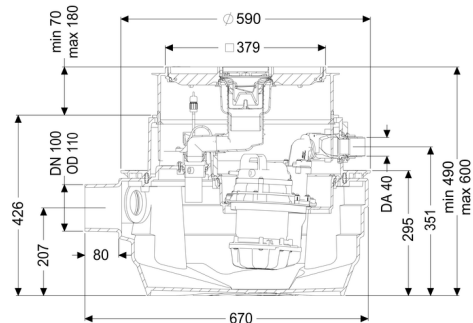

Article information

Item no.: 28701XC
 GTIN: 4026092093641
 Price group: 20

Advantages

- Suitable for complete basement drainage
- Integrated drainage function when installed in the floor slab
- Maximum operating reliability due to intelligent control unit (Duo)

Description

The lifting station for faecal and faecal-free wastewater is equipped with a submersible pump and a backflow preventer. The collection tank made of permanently resistant polymer (PE) has an enclosed pump tank. One-handed closures enable easy removal of the integrated components.

The station is controlled by a user-friendly control unit, which is optionally integrated in the building management system via a potential-free contact or alarm and collective fault messages that can be output via a GSM interface.

Type of wastewater: wastewater with sewage
 Installation situation: floor slab installation

Version:

Type of system: Single station
 Shut-off valve: without shut-off valve
 Odour trap: Multistop
 Type of waterproofing layer: Waterproofing layer
 Pump control: Control unit
 Backflow preventer: integrated

Resistant: Resistant to saline media, wastewater from water softening systems and wastewater containing condensate from heating systems

Delivery state: Pre-mounted for final assembly on site (pumps and sensor system must be fitted on site and control unit must be connected)

General characteristics:

Colour: black

Approval: Z-53.2-484

Dimensions:

Length: 670 mm

Width: 590 mm

Cutout dimension, length: 800 mm

Cutout dimension, width: 800 mm

Tank:

Number of inlets: 1 ST

Inlet nominal size (DN): 100

Inlet nominal size (OD): 110 mm

Distance pipe bottom inlet to tank bottom: 152 mm

Distance from centre of outlet pipe to tank bottom: 351 mm

Distance from centre of inlet pipe to tank bottom: 207 mm

Distance pipe bottom outlet to tank bottom: 351 mm

Connection conduit pipe (DN): 50 mm

Tank volume: 40 l

Pumping volume: 20 l

Pressure pipe connection: horizontal

Pressure pipe connection (DN): 32 mm

Pressure pipe connection (OD): 40 mm

Installation depth: 490 - 600 mm

Venting connection (DN): 70 mm

Vertical adjustment: vertically adjustable upper section

Coverage features:

Type of cover: tileable cover plate

Cover material: Polymer

Drainage function:	yes
Max. flooring height:	16 mm
Length:	366 mm
Width:	366 mm
Locking:	Lock & Lift

Pumping device:

Number of pumps:	1
Max. pumping capacity:	11.5 m ³ /h
Max. pumping height:	10 m
Operating voltage:	230 V
Mains frequency:	50 Hz
Operating mode:	S3 - 50 %
Power P1:	1.2 kW
Power P2:	0.69 kW
Speed:	2,800 U/min
Type of fuse required (electrical protection):	Fuse protection through control unit 230 V
Max. temperature (permanent) of conveyed material:	40 °C
Connection type:	coded plug
Weight:	10 kg
Impeller type:	Macerator
Length of mains cable for pump:	5 m
Rated current:	5.2 A
Protection class (pump):	IP 68
Protection class:	I
Type of pump connection cable:	H07RN-F 3G 1.0 mm ²
Temperature monitoring:	integrated
Cos phi - power factor:	0.97
Insulation class:	F

Control:

Control unit:	Comfort
Operating voltage:	230 V
Mains frequency:	50 Hz
Self-diagnosis system (SDS):	yes
Battery buffering:	yes
Multi-line display:	yes
Log book function:	yes
USB interface:	yes
GSM interface:	yes
Potential-free contact:	optional
Type of fuse required (electrical protection):	C 16 A
Motor protection switch:	yes
Protection class control unit:	IP 54
Length of mains cable for control unit:	1.4 m
Type of level measurement:	pneumatic

Level measurement instrument:
Alarm sensor:

Immersion pipe
optical probe