

## Lifting station Aqualift S 200 Duo, GTF 1250, Free-standing set-up

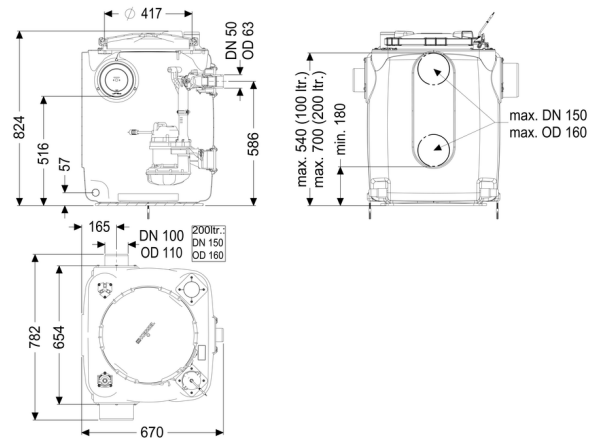

### Article information

Item no.: 28518  
 GTIN: 4026092092941  
 Price group: 20

### Advantages

- 1. With odour-tight cover and quick-release closure for easy maintenance
- 2. Tank made of PE, resistant to aggressive wastewater
- 3. Including backflow preventer for the pressure pipe

### Description

Lifting station for faecal-free wastewater, free-standing set-up, preassembled for final installation on site.

- With odour-tight cover and quick-release closure for easy maintenance
- Tank made of PE, resistant to aggressive wastewater
- Including backflow preventer for the pressure pipe
- Including socket DN 100 and DN 150 for inlet and sampling
- Integrated sampling possibility
- Pumps with multi-vane impeller for maximum operating reliability
- Including control unit for recording level and alarm detection

Type of wastewater: wastewater without sewage  
 Installation situation: free-standing set-up

### Version:

Type of system: Twin pump station  
 Pump control: Control unit  
 Backflow preventer: integrated

Delivery state: Pre-mounted for final assembly on site (pumps and sensor system must be fitted on site and control unit must be connected)

### General characteristics:

Colour: black  
Standard: EN 12050-2

### Dimensions:

Length: 670 mm  
Width: 655 mm  
Height: 815 mm

### Tank:

Inlet nominal size (DN): 100  
Tank volume: 220 l  
Pumping volume: 100 l  
Pressure pipe connection (DN): 50 mm  
Pressure pipe connection (OD): 63 mm

### Coverage features:

Type of cover: Cover  
Cover material: Polymer  
Colour of cover: violet  
Tightness: odour-tight  
Locking: Quick-release closure

Free passage: 30 mm

### Pumping device:

Pump: GTF 1250  
Number of pumps: 2  
Max. pumping capacity: 20 m<sup>3</sup>/h  
Max. pumping height: 11 m  
Operating voltage: 230 V  
Mains frequency: 50 Hz  
Operating mode: S1  
Power P1: 1.3 kW  
Power P2: 0.8 kW  
Speed: 2,700 U/min  
Type of fuse required (electrical protection): C 16 A

Max. temperature (permanent) of conveyed material:	40 °C
Connection type:	coded plug
Weight:	10 kg
Impeller type:	Multi-vane impeller
Length of mains cable for pump:	5 m
Rated current:	5.4 A
Protection class (pump):	IP 68 (3m)
Protection class:	I
Type of pump connection cable:	H07RN-F 3G 1.0 mm <sup>2</sup>
Temperature monitoring:	integrated
Insulation class:	F

### **Control:**

Control unit:	Comfort
Operating voltage:	230 V
Mains frequency:	50 Hz
Self-diagnosis system (SDS):	yes
Battery buffering:	yes
Multi-line display:	yes
Log book function:	yes
USB interface:	yes
GSM interface:	yes
Potential-free contact:	optional
Motor protection switch:	yes
Protection class control unit:	IP 54
Length of mains cable for control unit:	1.4 m
Type of level measurement:	pneumatic
Alarm sensor:	Immersion pipe