

Lifting station Aqualift S Compact Duo, GTF 500, Floor slab, tileable

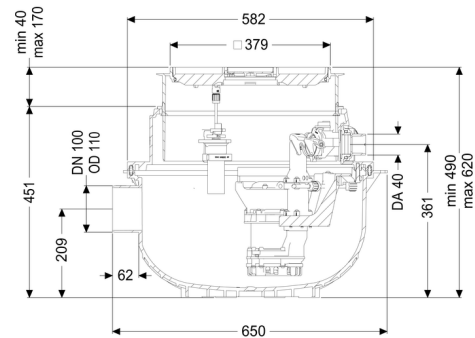

Article information

Item no.: 280530X
 GTIN: 4026092082690
 Price group: 20

Advantages

- System ready to plug in
- Easy retrofitting from Mono to Duo possible
- Quiet operation, as the pump installation does not cause any structure-borne sound emissions.

Description

The ready to plug in lifting station for faecal-free wastewater is equipped with a submersible pump and a backflow preventer. The collection tank made of permanently resistant polymer (PE) has an open pump tank. One-handed closures enable easy removal of the integrated components. The system for installation in the floor slab is preassembled for final installation on site.

The station is controlled optionally by a float switch (Mono) or a user-friendly control unit (Tronic and Duo), which are optionally integrated in the building management system via a potential-free contact or alarm and collective fault messages can be output via a GSM interface.

- with telescopic upper section for continuously adjustable height and level compensation and integrated floor drain
- collection tank made of PE, resistant to aggressive wastewater and 3 m groundwater
- including backflow preventer for the pressure pipe
- including sockets for inlet and cable conduit
- pump with multi-vane impeller for maximum operating reliability

Type of wastewater: wastewater without sewage
 Installation situation: floor slab installation

Version:

Type of system:	Twin pump station
Pump control:	Control unit
Backflow preventer:	integrated
Delivery state:	Installation-ready (connection parts must be connected on site)

General characteristics:

Colour:	black
Standard:	EN 12050-2

Dimensions:

Length:	617 mm
Width:	585 mm

Tank:

Inlet nominal size (DN):	100
Pumping volume:	20 l
Pressure pipe connection (DN):	32 mm
Pressure pipe connection (OD):	40 mm
Installation depth:	490 - 620 mm
Vertical adjustment:	vertically adjustable upper section

Coverage features:

Type of cover:	tileable cover plate
Cover material:	Polymer
Colour of cover:	silver grey
Drainage function:	yes
Max. flooring height:	16 mm
Load class:	K 3 (EN 1253-1)
Length:	366 mm
Width:	366 mm
Locking:	Lock & Lift
Free passage:	10 mm

Pumping device:

Pump:	GTF 500
Number of pumps:	2
Max. pumping capacity:	10 m ³ /h

Max. pumping height:	8 m
Operating voltage:	230 V
Mains frequency:	50 Hz
Operating mode:	S1
Power P1:	0.6 kW
Power P2:	0.36 kW
Speed:	2,800 U/min
Type of fuse required (electrical protection):	C 16 A
Max. temperature (permanent) of conveyed material:	40 °C
Connection type:	coded plug
Impeller type:	Multi-vane impeller
Length of mains cable for pump:	5 m
Rated current:	2.7 A
Protection class (pump):	IP 68 (3m)
Type of pump connection cable:	H07RN-F 3G 1.0 mm ²
Temperature monitoring:	integrated

Control:

Control unit:	Comfort
Operating voltage:	230 V
Mains frequency:	50 Hz
Self-diagnosis system (SDS):	yes
Battery buffering:	yes
Multi-line display:	yes
Log book function:	yes
USB interface:	yes
GSM interface:	yes
Potential-free contact:	optional
Protection class control unit:	IP 54
Connection type:	coded plug
Length of mains cable for control unit:	1.4 m
Type of level measurement:	pneumatic
Level measurement instrument:	Immersion pipe
Alarm sensor:	optical probe